

**ASSEMBLY INSTRUCTIONS**

DIFFERENT TRAINS BY MATTHEW HILTON

PARTS

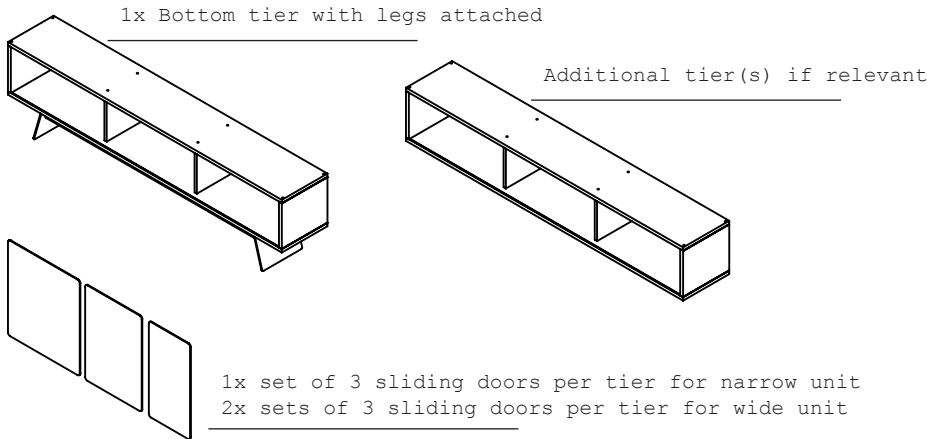

HARDWARE

(10x) M8x35 bolts per tier ordered



YOU WILL NEED

5mm heavy duty Allen Key  
The help of a friend

NOTES

NOTE 1: Be certain that all assembly is carried out on a flat and stable surface. This will ensure a good final result. Reverse the steps to disassemble the piece.

NOTE 2: Your furniture arrives packed in numerous layers that protect it during transport. It is important that you remove the packaging carefully to avoid damaging your furniture. Refer to our information sheet "Unpacking Your Furniture" for further details.

NOTE 3: Great care is required when assembling our products as they can mark very easily if banged or dropped. Use blankets to soften the assembly surface - hard surfaces such as wood or stone flooring may damage the furniture if in direct contact.

NOTE 4: We advise that assembly and disassembly of De La Espada furniture is undertaken by a minimum of 2 people.

NOTE 5: When screwing in bolts, tighten well, but be sure NOT TO OVERTIGHTEN. This can cause the thread to strip thus resulting in a poor connection.

NOTE 6: To prevent injury, it is important to complete the assembly of the main body before attaching the sliding doors.

O  
1  
M  
A  
T  
T  
H  
E  
W  
W  
H  
I  
L  
T  
O  
N

**ASSEMBLY INSTRUCTIONS CONTINUED**

DIFFERENT TRAINS

INSTRUCTIONS

1) ASSEMBLE THE MAIN BODY

a) Identify the order of modules. The first (bottom) module has the leg frame attached and has pre-drilled holes in the top surface. The last (top module) has ten metal inserts along the bottom surface only. Any modules in between have metal inserts along the bottom and pre-drilled holes along the top.

NOTE: Connect the modules one at a time. Do NOT stack all modules at the same time.

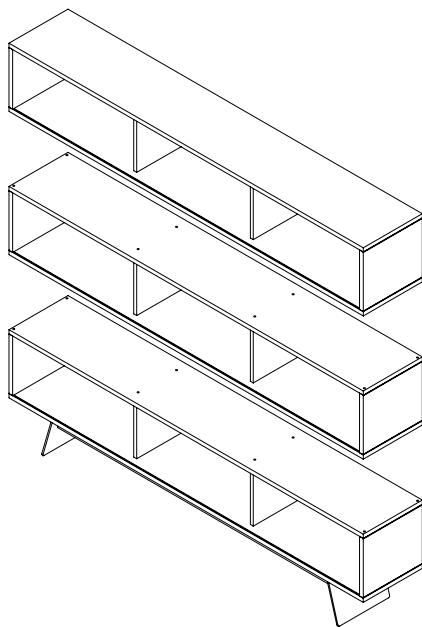

b) Place the second module on top of the first module, and align the holes. Insert an M8 conic bolt into the pre-drilled holes and into the matching metal inserts and tighten firmly with a 5mm Allen Key, but do not overtighten.

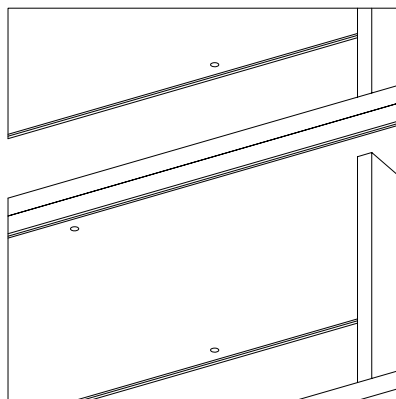
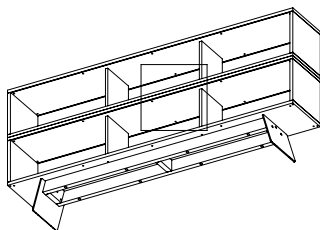

0  
2  
M  
A  
T  
T  
H  
E  
W  
H  
I  
L  
T  
I  
O  
N

**ASSEMBLY INSTRUCTIONS CONTINUED**  
**DIFFERENT TRAINS**

c) Repeat this operation for all remaining modules.

2) ATTACH THE DOORS

NOTE: Each sliding door is the same on the top and bottom so may be attached in either orientation.

a) Place the top lip of the door into the top recess of your chosen module.

b) With the top lip in place, push the door upward,, and fit the bottom of the door into the bottom lip of the module.

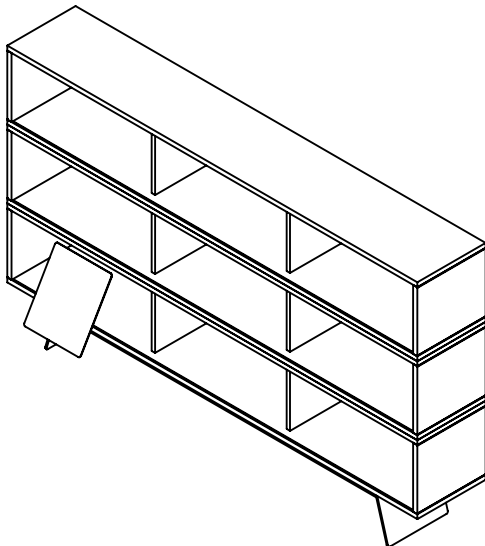

c) Repeat the above operation for all sliding doors.

3) The assembly is now complete and your Different Trains cabinet is ready for use.

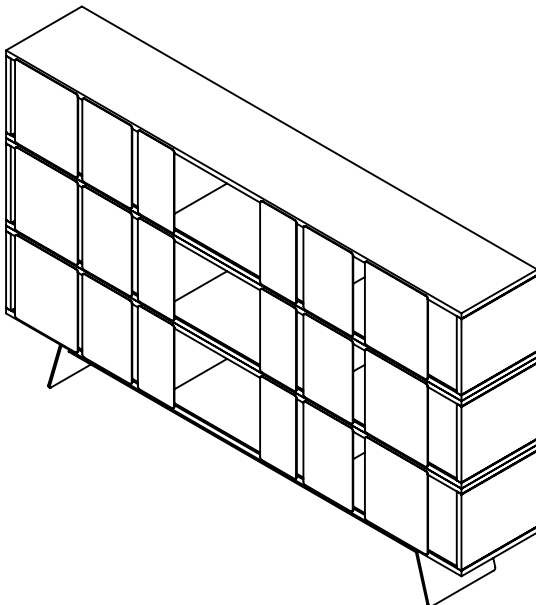

0  
3  
M  
A  
T  
T  
H  
E  
W  
H  
I  
L  
E  
I  
C  
O  
N